

High Efficiency, High Power Factor Preregulator

PRELIMINARY
FEATURES

- Programmable PWM Frequency Foldback for Higher Efficiency at Light Loads
- Leading Edge PWM for Reduced Output Capacitor Ripple Current
- Controls Boost PWM to Near Unity Power Factor
- World Wide Operation without Switches
- Accurate Power Limiting
- Synchronizable Oscillator
- 100 μ A Startup Supply Current
- Low Power BCDMOS
- 12V to 18V Operation

DESCRIPTION

The UCC3858 provides all of the functions necessary for active power factor corrected preregulators which require high efficiency at low power operation. The controller achieves near unity power factor by shaping the AC input line current waveform to correspond to the AC input line voltage using average current mode control.

The operation of the UCC3858 closely resembles that of previously designed Unitrode PFC parts with additional features to allow higher efficiency boost converter operation at light loads. This is accomplished by linearly scaling back the PWM frequency when the output of the voltage error amplifier drops below a predetermined user programmable level indicating a light load condition. The frequency is scaled back by reducing the charging current for the CT ramp (in proportion to the output power), and increasing the dead time. There is also an instantaneous reset input to pull the IC out of fold-back mode quickly when the load comes back up.

The PWM technique used in the UCC3858 is leading edge modulation. When combined with the more conventional trailing edge modulation on the downstream converter, this scheme offers the benefit of reduced ripple current on the bulk storage capacitor. The oscillator is designed for easy synchronization to the downstream converter. A simple synchronization scheme can be implemented by connecting the PWM output of the downstream converter to the SYNC pin.

Controller improvements include an onboard peak detector for the input line RMS voltage, an integrated overcurrent shutdown, overvoltage shutdown and significantly lower quiescent operating current. The peak detector eliminates an external 2-pole low pass filter for RMS detection. This simplifies the converter design as well as providing an approximate 6X improvement in input line transient response. The current signal is

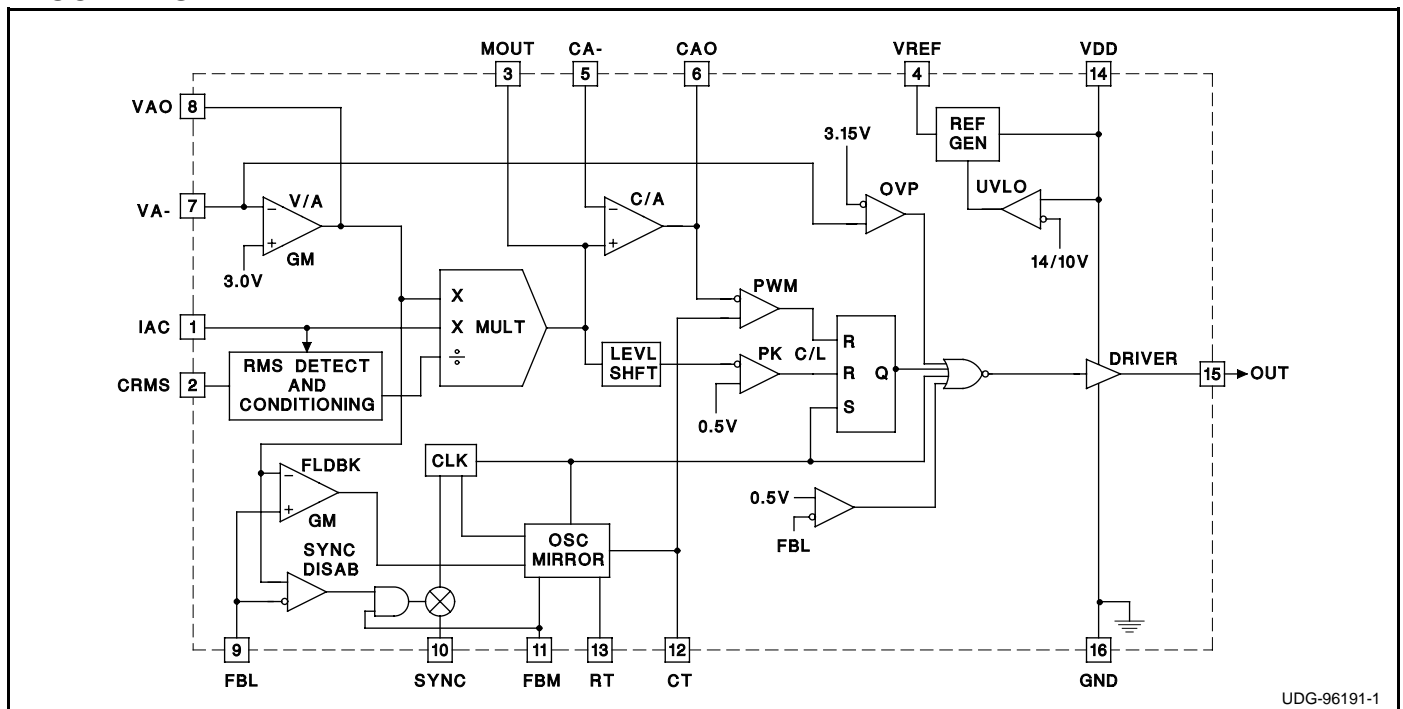
continued
BLOCK DIAGRAM

UDG-96191-1

DESCRIPTION (cont.)

extracted from the current error amplifier input to provide a cycle-by-cycle peak current limit. Low startup and operating currents which are achieved through the use of Unitrode's BCDMOS process simplify the bootstrap supply design as well as minimize losses in the control circuit. A transconductance voltage error amplifier allows output voltage sensing for internal overvoltage protection.

Additional features include: undervoltage lockout for reliable off-line startup, a precision 7.5V reference, and a precision RMS detection and signal conditioning circuit. Chip shutdown can be attained by bringing the FBL pin below 0.5V.

ABSOLUTE MAXIMUM RATINGS

Supply Voltage V _{DD}	18V
Gate Drive Current	
Continuous	0.2A
Pulsed	500mA
Input Voltage, CA-, MOUT, VA-	11V
Input Current IAC	200mA
Power Dissipation	1W
Storage Temperature	-65°C to +150°C
Junction Temperature	-55°C to +150°C
Lead Temperature (Soldering, 10 Sec.)	+300°C

Unless otherwise indicated, voltages are reference to ground and currents are positive into, negative out of the specified terminal. Pulsed is defined as a less than 10% duty cycle with a maximum duration of 500ns. Consult Packaging Section of Databook for thermal limitations and considerations of packages.

ELECTRICAL CHARACTERISTICS: Unless otherwise stated, these specifications apply for T_A = 0°C to 70°C for the UCC3858, -40°C to +85°C for the UCC2858, and -55°C to +150°C for the UCC1858, V_{DD} = 12V, RT = 24k, CT = 330pF, R_{F_{BM}} = 96k, IAC = 100μA, T_A = T_J.

PARAMETER	TEST CONDITIONS	MIN	TYP	MAX	UNITS
Overall					
Supply Current, Off	CAO, VAO = 0V, VDD = UVLO - 0.3V		60		μA
Supply Current, On			3.5		mA
VDD Turn-On Threshold			13.75	15.5	V
VDD Turn-Off Threshold		9	10		V
UVLO Hysteresis			TBD		V
Voltage Amplifier					
Input Voltage	T _A = 25°C	2.95	3	3.05	V
Over Voltage Protection		3.1	3.15	3.2	V
VA- Bias Current			1		μA
Open Loop Gain	V _{OUT} = 2V to 5V		60		dB
VAO High	Load = -50μA		6		V
VAO Low	Load = 50μA		0.3	0.5	V
Output Source Current	V _{VA-} = 2.8V		-50		μA
Output Sink Current	V _{VA-} = 3.2V		50		μA
Transconductance			500		μS
Current Amplifier					
Input Offset Voltage	V _{CM} = 0V, V _{CAO} = 3V	-3	0	3	mV
Input Bias Current	V _{CM} = 0V, V _{CAO} = 3V		5		μA
Input Offset Current	V _{CM} = 0V, V _{CAO} = 3V		0.5		μA
Open Loop Gain	V _{CM} = 0V, V _{CAO} = 2V to 5V		90		dB
CMRR	V _{CM} = 0V to 1.5V, V _{CAO} = 3V		80		dB
CAO High	V _{CA-} = 0V, V _{MOUT} = 1V		6		V
CAO Low	V _{CA-} = 1V, V _{MOUT} = 0V		0.2		V
Maximum Output Source Current			-150		μA
Maximum Output Sink Current			1		mA
Gain Bandwidth Product		3	5		MHz
Voltage Reference					
Output Voltage	I _{REF} = 0mA, T _A = 25°C	7.387	7.5	7.6	V
	Over Temperature, UCC3858	7.368	7.5	7.631	V
	Over Temperature, UCC2858, UCC1858	7.313	7.5	7.687	V

ELECTRICAL CHARACTERISTICS (cont.): Unless otherwise stated, these specifications apply for TA = 0°C to 70°C for the UCC3858, -40°C to +85°C for the UCC2858, and -55°C to +150°C for the UCC1858, VDD = 12V, RT = 24k, CT = 330pF, RFBM = 96k, IAC = 100µA, TA = TJ.

PARAMETER	TEST CONDITIONS	MIN	TYP	MAX	UNITS
Voltage Reference (cont.)					
Load Regulation	IREF = 1mA to 10mA		2		mV
Line Regulation	VDD = 12V to 18V		2		mV
Short Circuit Current	VREF = 0V		35		mA
Oscillator					
Initial Accuracy	TA = 25°C	85	100	115	kHz
Voltage Stability	VDD = 12V to 18V		1		%
Total Variation	Line, Temperature	80		120	kHz
Ramp Amplitude (p-p)	Oscillator Free Running, VAO = 5.5V	3.2	3.5	3.8	V
Ramp Peak Voltage		4	4.5	5	V
Peak Current Limit					
PKLMT Reference Voltage		450	500	550	mV
PKLMT Offset Voltage			100		mV
PKLMT Propagation Delay			1		µs
Multiplier					
Output Current, IAC Limited	IAC = 100µA, VAO = 5.5V, VCRMS = 0V		-200		µA
Output Current, Power Limited	IAC = 100µA, VAO = 5.5V, VCRMS = 1V		-200		µA
Output Current, Zero	IAC = 0µA	-2	0	2	µA
Gain Constant			2.5		1/V
PWM Frequency Foldback					
FBL Offset			15		mV
FBL Input Current			100		nA
FBM Reference			4.5		V
FBM Foldback Override			1.5		V
Gate Driver					
Pull Up Resistance	OUT = 5V		4.7		Ω
Pull Down Resistance	OUT = 5V		2.5		Ω
Output Rise Time	CLOAD = 1nF, Rs = 10Ω		25		ns
Output Fall Time	CLOAD = 1nF, Rs = 10Ω		10		ns

PIN DESCRIPTIONS

CA-: (Current Amplifier Inverting Input) This input and the non-inverting input MOUT remain functional down to GND.

CAO: (Current Amplifier Output) Output of a wide bandwidth amplifier that senses line current and commands the pulse width modulator (PWM) to force the correct current. This output can swing close to GND, allowing the PWM to force zero duty cycle when necessary.

CRMS: (RMS Measurement Capacitor) A capacitor connected between CRMS and GND enables averaging of the AC line voltage over a half cycle. IAC current is internally mirrored to provide charging current for CRMS.

CT: (Oscillator Timing Capacitor) A capacitor from CT to GND will set the free-running PWM oscillator frequency according to:

$$f = \frac{0.771}{RT \cdot CT}$$

FBL: (Frequency Foldback Level Select) Selects the level of the voltage error amplifier output at which frequency foldback begins. A chip shutdown can be attained by bringing the foldback level pin to below 0.5V.

FBM: (Minimum Frequency Reference) A resistor between this pin and VREF is used to set the minimum frequency during foldback mode. Once the value of RT and CT are determined, use

$$R_{FBM} \approx \frac{1}{CT \cdot f_{MIN}} - RT$$

to find the value of RFBM which will set the minimum foldback frequency to fMIN. This pin also incorporates a

PIN DESCRIPTIONS (cont.)

foldback override which enables the part to return quickly to normal operating mode when the load comes back up. To override foldback mode, force this pin below 1.5V with an open collector.

GND: (Ground) All voltages measured with respect to ground. VDD and VREF should be bypassed directly to GND with a 0.1 μ F or larger ceramic capacitor. The timing capacitor discharge current also returns to this pin, so the lead from CT to GND should be as short and direct as possible.

IAC: (Input AC Current) This input to the analog multiplier is a current. The multiplier is tailored for very low distortion from this current input (IAC) to MOUT. Requires some bypassing to GND for noise filtering (<470pF).

MOUT: (Multiplier Output) The output of the analog multiplier and the non-inverting input of the current amplifier are connected together at MOUT. As the multiplier output is a current, this is a high impedance input so the amplifier can be configured as a differential amplifier to reject ground noise. The voltage at this pin is also used to implement peak current limiting.

OUT: (Gate Drive Output) The output of the PWM is a totem pole MOSFET gate driver. A series gate resistor of at least 5 Ω is recommended to prevent interaction between the gate impedance and the output driver that might cause the gate drive to overshoot excessively.

RT: (Oscillator Timing Resistor) A resistor from RT to GND is used to program oscillator discharge current.

SYNC: (Oscillator Synchronization Input) Allows the PFC

to be synchronized to a trailing edge modulator in the DC-DC stage. A synchronization pulse can be generated from the positive output edge of the downstream regulator and applied to this pin. The internal clock is reset (charged up) on the rising edge of the SYNC input.

VA-: (Voltage Amplifier Inverting Input) This pin is normally connected to the boost converter output through a divider network. It also is an input to the overvoltage comparator where by the output is terminated if this pin's voltage exceeds 3.15V.

VAO: (Voltage Amplifier Output) Output of the transconductance amplifier that regulates output voltage. The voltage amplifier output is internally limited to approximately 6V for power limiting. It is also used to determine the frequency foldback mode. Compensation network is connected from this pin to GND.

VDD: (Positive Supply Voltage) Connect to a stable source of at least 20mA between 13V and 17V for normal operation. Bypass VDD directly to GND to absorb supply current spikes required to charge external MOSFET gate capacitance. To prevent inadequate gate drive signals, the output devices will be inhibited unless VDD exceeds the upper undervoltage lockout voltage threshold and remains above the lower threshold.

VREF: (Reference Voltage) VREF is the output of an accurate 7.5V voltage reference. This output is capable of delivering 10mA to peripheral circuitry and is internally short circuit current limited. VREF is disabled and will remain at 0V when VDD is low. Bypass VREF to GND with a 0.1 μ F or larger ceramic capacitor for best stability.

APPLICATION INFORMATION

The UCC3858 is designed to optimize the implementation of power factor corrected boost converters in low to medium power applications where light load efficiency is critical. While basic configuration of the UCC3858 is similar to the industry standard UC3854 series controllers, several distinguishing features have been added. A typical application circuit is shown along with a diagram showing how the UCC3858 can be used with the downstream converter to achieve optimum performance.

Chip Bias Supply and Startup

The UCC3858 is implemented using Unitrode's BCDMOS process allowing minimal startup (60 μ A typical) and operating (3.5mA typical) supply currents. This results in significantly lower power consumption in the trickle charge resistor used to startup the IC, increasing the system efficiency at light loads. Lower supply currents, coupled with the wide undervoltage lockout hysteresis (13.75V on, 10V off) provide the opportunity to operate both stages from

the same startup and bootstrap supply as shown in the typical application drawing.

Oscillator and Frequency Foldback at Light Loads

The oscillator of the UCC3858 is set up to operate either synchronously with the downstream converter or as a stand alone oscillator. A simplified block diagram of the oscillator and associated circuitry is shown in Figure 2 and the related waveforms are shown in Figures 3a - 3c. A rising edge at the SYNC pin initiates the clock cycle by charging up the CT pin with a nominal internal current of ICHnom (=19 • IDIS). Once the high threshold of the ramp (4.5V) is crossed, the internal latch is set and the CT pin starts discharging at a rate (IDIS=3/RT) set by the resistor on the RT pin. In the absence of a SYNC pulse, CT discharges all the way to the ramp low threshold (1V) and that sets the free running frequency of the oscillator as given by equation 1. In applications where synchronization is used, the RT, CT values should be chosen so that

APPLICATION INFORMATION (cont.)

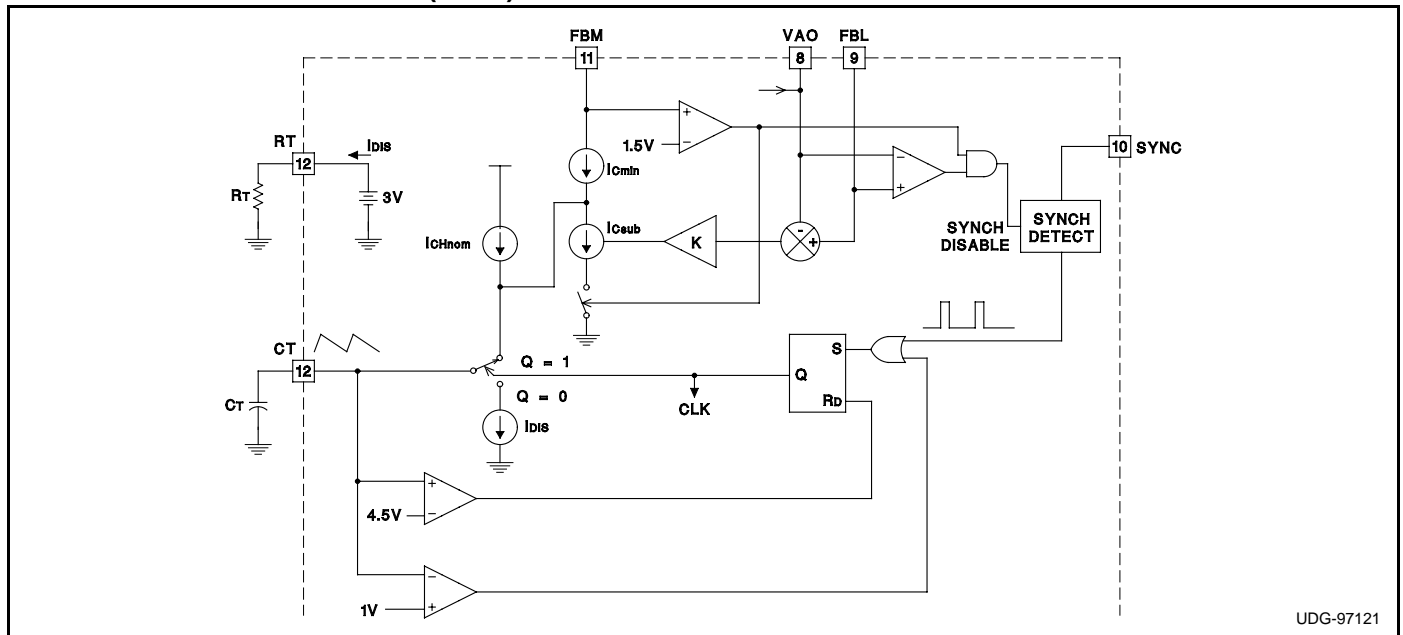

Figure 2. Oscillator Block Diagram

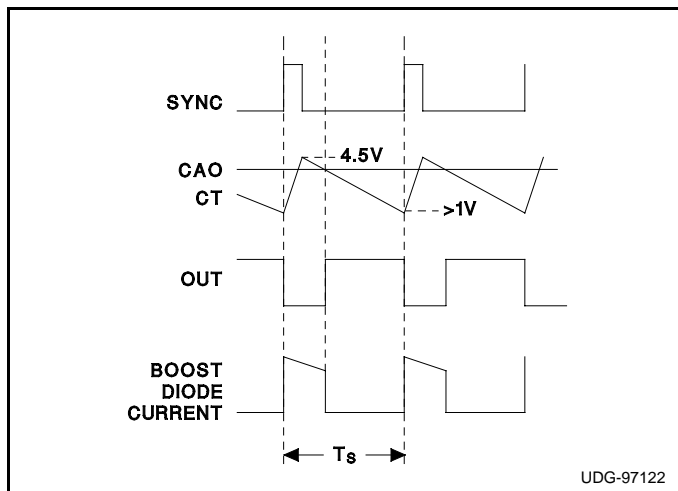

Figure 3a. Oscillator Timing Waveforms Synchronized to Buck (DC/DC) PWM

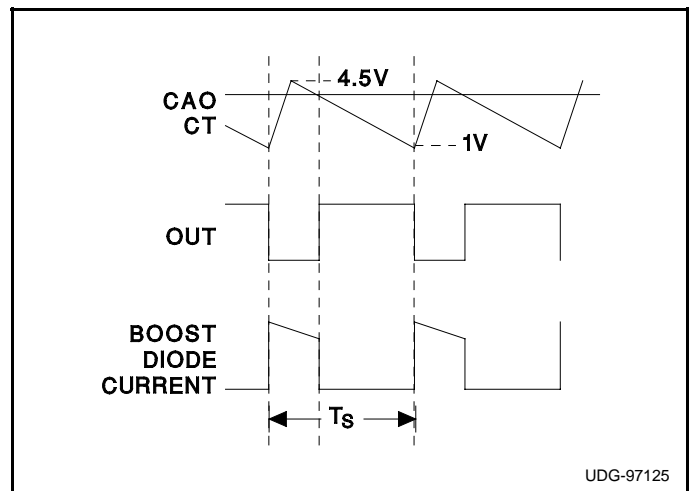

Figure 3b. Oscillator Timing Waveforms Standalone Operation

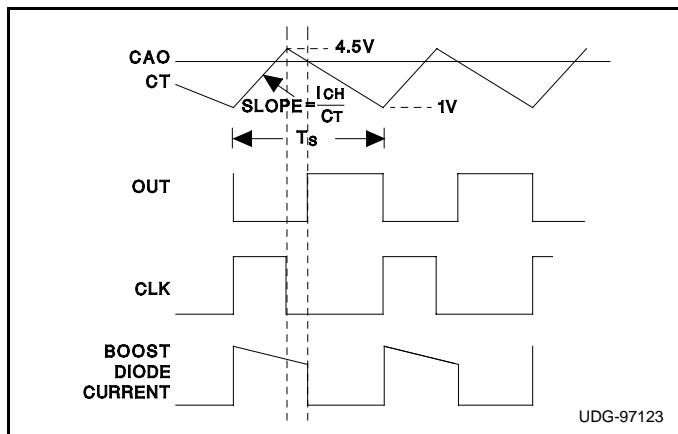

Figure 3c. Frequency Foldback Mode

the free running frequency is always lower than the synchronization frequency.

$$f_{Snom} = \frac{19}{20} \cdot \frac{3}{3.5} \cdot \frac{1}{R_T C_T} \quad (1)$$

When VAO falls below the threshold level set by FBL, the oscillator goes into frequency foldback mode and disables synchronization. The frequency foldback is achieved by reducing the oscillator charging current as the power level (and VAO voltage) falls. As shown in Figure 2, the difference between VAO and FBL regulates current I_{Csub} which subtracts the current available for charging CT. The effective charge current into the capacitor is given by $(I_{CHnom} - I_{Csub})$. To avoid converter opera-

APPLICATION INFORMATION (cont.)

tion in the low frequency range (e.g. audio), the charge current should not be allowed to go very low. Minimum frequency of the controller is programmed by the current I_{MIN} flowing into pin FBM which sets the minimum charging current. The value of R_{FBM} to set the desired minimum frequency is given by:

$$R_{FBM} = \frac{3}{3.5} \cdot \frac{1}{f_{Smin} \cdot C_T} - R_T \tag{2}$$

When the converter comes out of the low power mode, the time taken to restore normal mode operation (return to nominal or synchronized frequency operation) must be minimized. Given that the voltage error amplifier response is very slow in PFC circuits, the VAO pin change is not the best indicator of change in load conditions. UCC3858 provides a solution where the normal mode can be restored instantaneously when FBM is pulled below 1.5V. A typical interface would involve the output of the error amplifier of the downstream converter (with proper buffering and filtering) driving an npn switch that pulls FBM down to GND. The buffer and filter should ensure that the switch is turned on only when the error amplifier of downstream converter is saturated high for a preset duration indicating a droop in output voltage from increased load. The FBM input can also be permanently pulled low to disable the frequency foldback mode completely, while still using the other features of UCC3858. FBL pin also acts as a chip disable input when it is brought below 0.5V.

Capacitor Ripple Reduction

For a power system where the PFC boost converter is followed by a DC-DC converter stage, there are benefits to synchronizing the two converters. In addition to the usual advantages such as noise reduction and stability, proper synchronization can significantly reduce the ripple currents in the boost circuit's output capacitor. Figure 4 helps illustrate the impact of proper synchronization by showing a PFC boost converter together with the simplified input stage of a forward converter. The capacitor current during a single switching cycle depends on the status of the

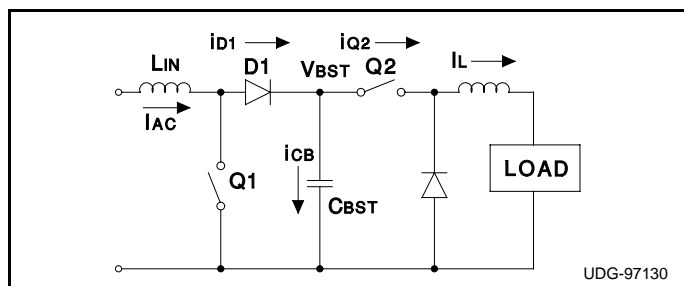

Figure 4. Simplified Representation of a 2-Stage PFC Power Supply

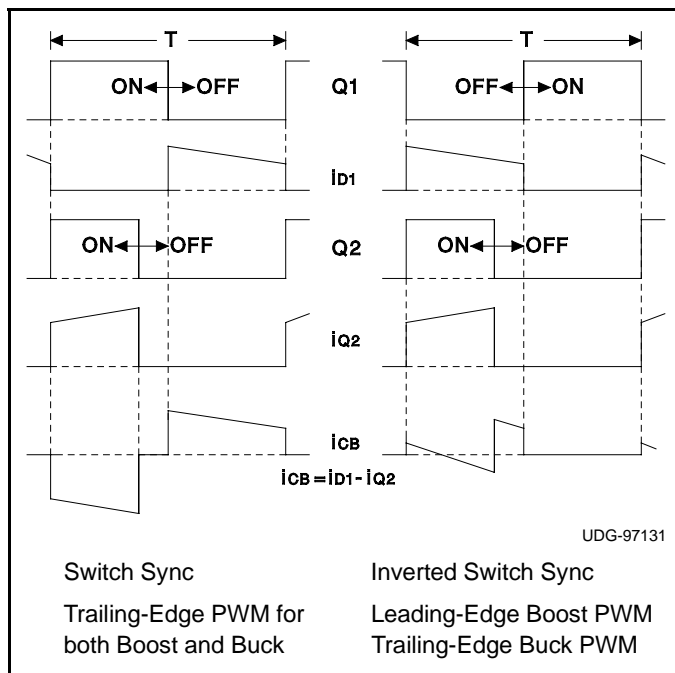

Figure 5. Timing Waveforms for Synchronization Scheme

switches Q1 and Q2 and is shown in Figure 5. It can be seen that with a synchronization scheme that maintains conventional trailing edge modulation on both converters, the capacitor current ripple is highest. The greatest ripple current cancellation is attained when the overlap of Q1 off-time and Q2 on-time is maximized. One method of achieving this is to synchronize the turn-on of the boost diode (D1) with the turn-on of Q2. This approach implies that the boost converter's leading edge is pulse width modulated while the forward converter is modulated with traditional trailing edge PWM. The UCC3858 is designed as a leading edge modulator with easy synchronization to the downstream converter to facilitate this advantage. Table I compares the I_{CBrms} for D1/Q2 synchronization as offered by UCC3858 vs. the I_{CBrms} for the other extreme of synchronizing the turn-on of Q1 and Q2 for a 200W power system with a V_{BST} of 385V.

	V _{IN} = 85V		V _{IN} = 120V		V _{IN} = 240V	
D (Q2)	Q1/Q2	D1/Q2	Q1/Q2	D1/Q2	Q1/Q2	D1/Q2
0.35	1.491A	0.835A	1.341A	0.663A	1.024A	0.731A
0.45	1.432A	0.93A	1.276A	0.664A	0.897A	0.614A

Table 1. Effects of Synchronization on Boost Capacitor Current

Table I illustrates that the boost capacitor ripple current can be reduced by about 50% at nominal line and about 30% at high line with the synchronization scheme facilitated by the UCC3858. The output capacitance value can be significantly reduced if its choice is dictated by ripple

APPLICATION INFORMATION (cont.)

current or the capacitor life can be increased as a result. In cost sensitive designs where hold-up time is not critical, this is a significant advantage.

An alternative method of synchronization to achieve the same ripple reduction is possible. In this method, the turn-on of Q1 is synchronized to the turn-off of Q2. While this method yields almost identical ripple reduction and maintains trailing edge modulation on both converters, the synchronization is much more difficult to achieve and the circuit can become susceptible to noise as the synchronizing edge itself is being modulated.

Reference Signal (IMULT) Generation

Like the UC3854 series, the UCC3858 has an Analog Computation Unit (ACU) which generates a reference current signal for the current error amplifier. The inputs to the ACU are (signals proportional to) instantaneous line voltage, input voltage RMS information and the voltage error amplifier output. Unlike prior techniques of RMS voltage sensing, UCC3858 employs a patent pending technique to simplify the RMS voltage generation and eliminate performance degradation caused by the prior techniques. With the novel technique (shown in Figure 6), need for external two pole filter for VRMS generation is eliminated. Instead, the IAC current is mirrored and used to charge an external capacitor (CRMS) during a half cycle. The voltage on CRMS takes the integrated sinusoidal shape and is given by equation 3. At the end of the half-cycle, CRMS voltage is held and converted into a 4-bit digital word for further processing in the ACU. CRMS is discharged and readied for integration during the next half cycle. The advantage of this method is that the second harmonic ripple on the VRMS signal is virtually elimi-

nated. Such second harmonic ripple is unavoidable with the limited roll-off of a conventional 2-pole filter and results in a 3rd harmonic distortion in the input current signal. The dynamic response to the input line variations is also improved as a new VRMS signal is generated every cycle.

$$V_{CRMS} = \frac{I_{ACpk}}{2 \cdot \omega \cdot C_{RMS}} \cdot (1 - \cos \omega t) \quad (3)$$

For proper operation, IACpk should be selected to be 100µA at peak line voltage. For universal input voltage with peak value of 265 VAC, this means RAC = 3.6M. The noise sensitivity of the IC requires a small bypass capacitor for high frequency noise filtering. The value of this capacitor should be limited to 330pF maximum. The VCRMS value should be approximately 1V at the peak of low line (80 VAC) to minimize any digitization errors. The peak value of VCRMS at high line then becomes 3.5V. The desired CRMS can be calculated from equation 3 to be 90nF for 50Hz line and 75nF for 60Hz line.

The multiplier output current is given by equation (4) with K=0.4.

$$I_{MULT} = \frac{(V_{VAO} - 0.5) \cdot I_{AC} \cdot K}{V_{CRMS}^2} \quad (4)$$

The multiplier peak current is limited to 200µA and the selected values for IAC and VCRMS should ensure that the current is within this range. Another limitation of the multiplier is that Imult can not exceed two times the IAC current, limiting the minimum voltage on VCRMS.

The discrete nature of the RMS voltage feedforward means that there are regions of operation where the input voltage changes, but the VRMS value fed into the multiplier does not change. The voltage error amplifier compensates for this by changing its output to maintain the required multiplier output current. When the output of the ADC changes, there is a jump in the output of the error amplifier. There is a resultant shift in the foldback frequency if the converter is at light load. However, the impact of this change is minimal on the overall converter operation.

Another key consideration with the RMS voltage scheme is that it relies on the zero-crossing of the IAC signal to be effective. At very light loads and high line conditions, the rectified AC does not quite reach zero if a large capacitor is being used for filtering on the rectified side of the bridge. In such instances, the feedforward effect does not take place and the controller functionality is lost. For UCC3858, the IAC current should go below 10µA for the zero crossing detection to take place. It is recommended that the capacitor value be kept low enough for the light

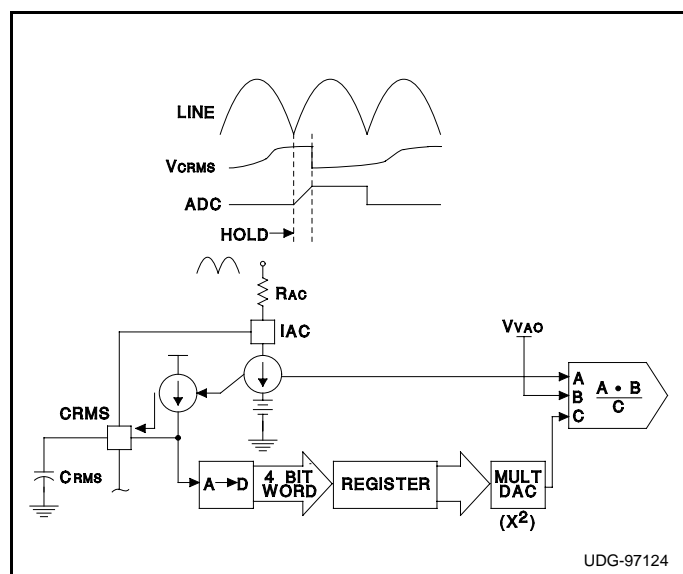

Figure 6. Novel Circuit for RMS Signal Generation

APPLICATION INFORMATION (cont.)

load operation or the feedforward be derived directly from the AC side of the input bridge as shown in the typical applications circuit.

Gate Drive Considerations

The gate drive circuit in UCC3858 is designed for high speed power switch drive. It consists of low impedance pull-up and pull-down DMOS output stages. When operating with high bias voltages, in order to stay within the SOA of the DMOS output stages, it is recommended that the gate drive current be limited to 0.5A peak with the use of external gate resistor. Please see the characteristic curve in Figure 7 for determining the required external resistance.

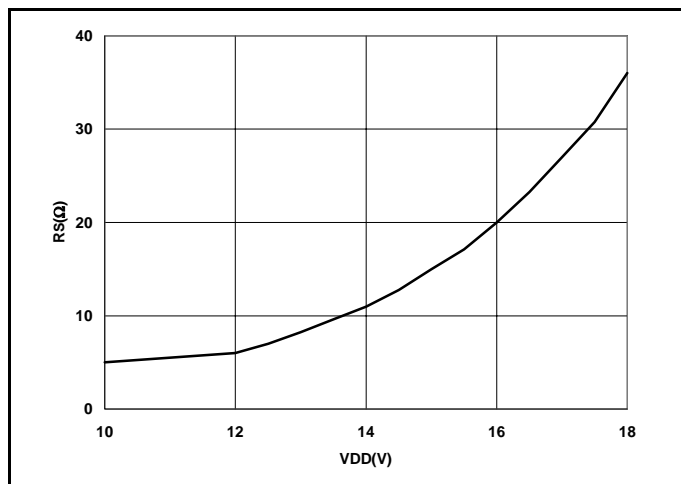

Figure 7. Required Series Gate Resistance as a Function of Supply Voltage

Current Amplifier Set-up

The multiplier is set-up first by choosing the V_{RMS} range. The maximum multiplier output is at low line, full load conditions. The inductor peak current also occurs at the same point. The multiplier terminating resistor can be determined using equation 5.

$$R_{MULT} = \frac{I_{Lpk} \cdot R_{SENSE}}{I_{MULTpk}} \quad (5)$$

The peak current limiting function provided by the UCC3858 is integrated into MOUT. The signal on MOUT is normally maintained at 0V as the $I_{MULT} \cdot R_{MULT}$ cancels the voltage drop across the sense resistor with closed loop operation. During short circuit or transient startup conditions, the multiplier current can not fully cancel the voltage drop across R_{SENSE} and the voltage at MOUT drops below 0V. The internal peak current limit is activated when MOUT drops below $-0.5V$. The peak current limit at any operating point is given by:

$$I_{LIM} = \frac{I_{MULT} \cdot R_{MULT} + 0.5}{R_{SENSE}} \quad (6)$$

The current amplifier can be compensated using previously presented techniques, (Application Note U-134), summarized here. A simplified high frequency model for inductor current to duty cycle transfer function is given by:

$$G_{ID}(s) = \frac{I_L}{D} = \frac{V_O}{sL} \quad (7)$$

The gain of the current feedback path at the frequency of interest (crossover) is given by:

$$\frac{D}{I_L} = R_{SENSE} \cdot \frac{R_Z}{R_I} \cdot \frac{1}{V_{SE}} \quad (8)$$

Where V_{SE} is the ramp amplitude (p-p) which is 3.5V for UCC3858. Combining equations 7 and 8 yields the loop gain of the current loop and equating it to 1 at the desired crossover frequency can result in a design value for R_Z . The current loop crossover frequency selected using conventional trade offs. However, it should be ensured that the current-loop is stable at the minimum switching frequency under foldback conditions.

Voltage Amplifier Set-up

The voltage amplifier in UCC3858 is a transconductance type amplifier to allow output voltage monitoring for an overvoltage condition. The gain of the amplifier, given by $G_M \cdot Z_V$, should be chosen to achieve desired attenuation of the output second harmonic ripple (as described in previous Unitrode Application Notes - U-134, U-159) while providing the best transient response.

APPLICATION INFORMATION (cont.)

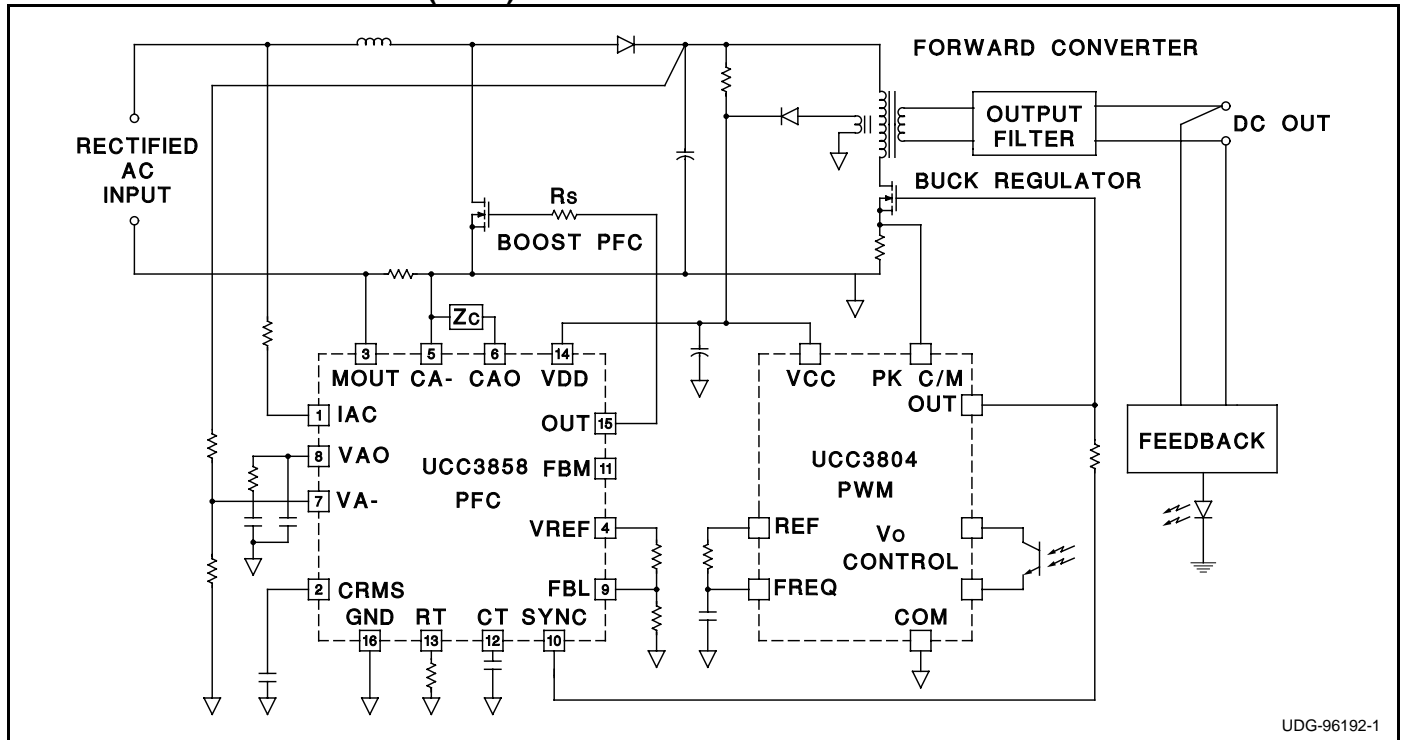

Figure 6. Use of the UCC3858 in a Two Stage Converter to Optimize Performance